

Product datasheet

Specifications



photo-electric sensor - XUM - reflex - Sn 2m - 12..24VDC - cable 2m

Local distributor code: 399309344 XUMTAPCNL2

EAN Code : 3389119061025

Main

Range of product	Telemecanique Photoelectric sensors XU
Series name	Application packaging
Electronic sensor type	Photo-electric sensor
Sensor name	XUM
Sensor design	Miniature
Detection system	Reflex
Material	Plastic
Type of output signal	Discrete
Supply circuit type	DC
Wiring technique	3-wire
Discrete output type	PNP
Discrete output function	1 NO or 1 NC programmable
Electrical connection	Cable
Cable length	2 m
Product specific application	Detection of transparent object
Emission	Infrared reflex
[Sn] nominal sensing distance	2 m reflex need reflector XUZC50 1 m reflex need reflector XUZC50CR

Complementary

Enclosure material	PBT
Lens material	PC
Output type	Solid state
Wire insulation material	PVC
Status LED	1 LED (yellow) for output state 1 LED (green) for supply
[Us] rated supply voltage	12...24 V DC
Supply voltage limits	10...30 V DC
Switching capacity in mA	<= 100 mA (overload and short-circuit protection)
Switching frequency	<= 250 Hz

Maximum voltage drop	<1.5 V (closed state)
Current consumption	<= 35 mA no-load
Maximum delay first up	15 ms
Maximum delay response	2 ms
Maximum delay recovery	2 ms
Setting-up	Sensitivity adjustment
Depth	77 mm
Height	92 mm
Length	11 mm
Width	31 mm
Net weight	0.2 kg

Environment

Product certifications	CSA CE UL
Ambient air temperature for operation	-25...55 °C
Ambient air temperature for storage	-40...70 °C
Immunity to ambient light	3000 lux natural light 3000 lux incandescent light
Vibration resistance	7 gn, amplitude = +/- 1.5 mm (f = 10...55 Hz) conforming to IEC 60068-2-6
Shock resistance	30 gn (duration = 11 ms) conforming to IEC 60068-2-27
IP degree of protection	IP67 double insulation conforming to IEC 60529 IP65 double insulation conforming to IEC 60529

Packing Units

Unit Type of Package 1	PCE
Number of Units in Package 1	1
Package 1 Weight	54.0 g
Package 1 Height	1.5 cm
Package 1 width	16.0 cm
Package 1 Length	20.0 cm
Unit Type of Package 2	S02
Number of Units in Package 2	48
Package 2 Weight	2.994 kg
Package 2 Height	15.0 cm
Package 2 width	30.0 cm
Package 2 Length	40.0 cm

Offer Sustainability

EU RoHS Directive	Pro-active compliance (Product out of EU RoHS legal scope) EU RoHS Declaration
Mercury free	Yes
RoHS exemption information	Yes

Contractual warranty

Warranty

18 months

Dimensions

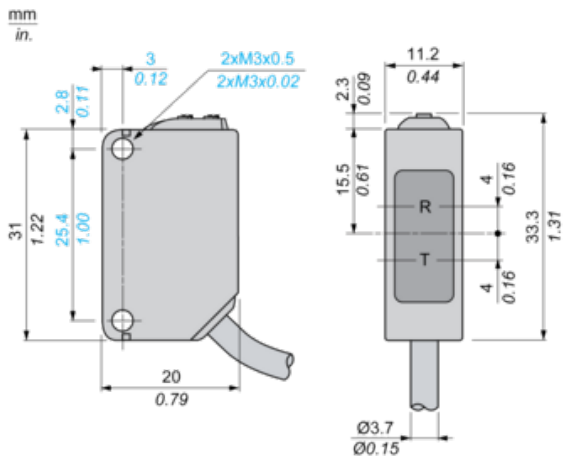

R : Reception
T : Transmission

Mounting

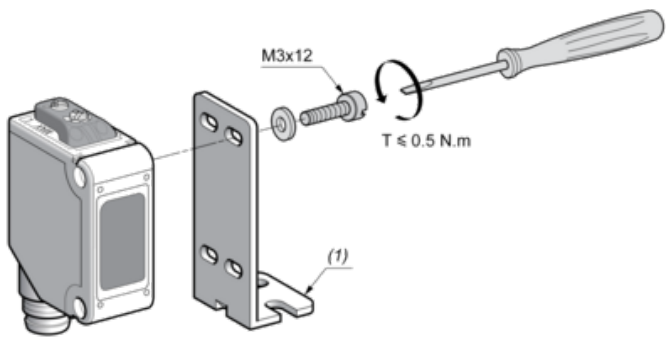

(1) Metal bracket

Wiring Schemes

PNP Output

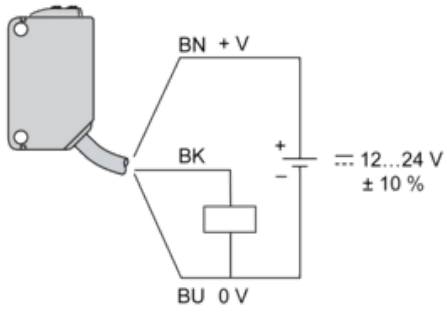

- BU** : Blue
- BN** : Brown
- BK** : Black (OUT)