

Product data sheet

Specifications



OEM MTG BASE QO MLO 240V 125A 3PH 24SP

QON324L125

Product availability : Stock - Normally stocked in distribution facility

Price* : 395.00 USD

Main

Marketing Trade Name	QO
Number of Spaces	24

Complementary

Wiring Configuration	3-wire
Product Certifications	CSA UL Listed

Ordering and shipping details

Category	00909-MOUNTING BASES, S/N
Discount Schedule	DE3A
GTIN	785901515197
Nbr. of units in pkg.	1
Package weight(Lbs)	4.5 lb(US) (2.04 kg)
Returnability	Yes
Country of origin	US

Offer Sustainability

Sustainable offer status	Green Premium product
California proposition 65	WARNING: This product can expose you to chemicals including: Lead and lead compounds, which is known to the State of California to cause cancer and birth defects or other reproductive harm. For more information go to www.P65Warnings.ca.gov
REACH Regulation	REACH Declaration
REACH free of SVHC	Yes
EU RoHS Directive	Compliant EU RoHS Declaration
Toxic heavy metal free	Yes
Mercury free	Yes
RoHS exemption information	Yes
China RoHS Regulation	China RoHS declaration Pro-active China RoHS declaration (out of China RoHS legal scope)

* Price is "List Price" and may be subject to a trade discount – check with your local distributor or retailer for actual price.

Contractual warranty

Warranty	18 months
----------	-----------

Dimensions

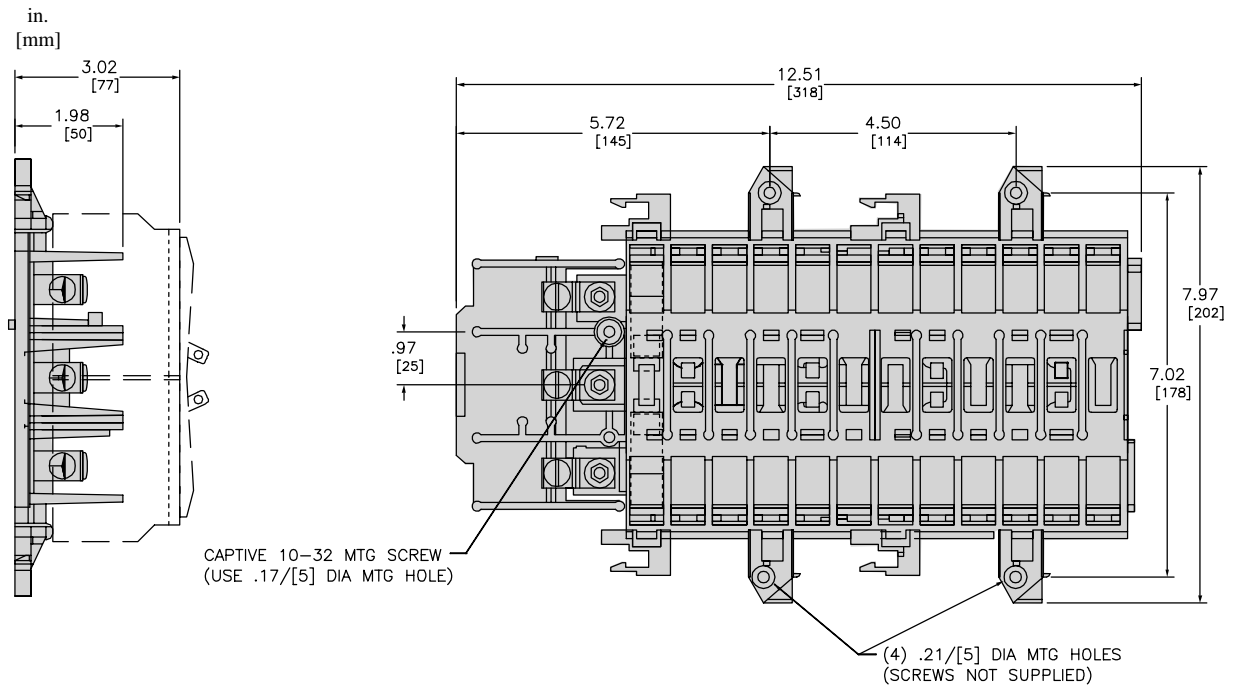

Wiring Diagram

